

Earthbag Options for Nepal:

Draft Guidelines for Reinforcement.

Patti Stouter May 21, 2015

Build Simple Inc., www.BuildSimple.org

Sustainable earthen buildings are strong in compression, but need help against tension or bending stresses. The barbed wire and vertical rebar in earthbag add important tensile strength.

More than 50 earthbag buildings in Nepal have recently survived 0.5- >0.7g of earthquake motion. Most mud block buildings don't survive 0.3 g forces. The forces in Nepal destroyed poorly reinforced as well as unreinforced masonry buildings around the earthbag structures, mud block and brick alike.

But earthbag is not magic. Standard earthbag construction has its limits. Adobe reinforcements that have performed well in New Zealand's >2 g seismic risk show us what earthbag needs to be ready for future quakes.

Here are three new options for building stronger earthbag, with medium levels for Nepal's 1g to 1.8 g risk areas. Owen Geiger and Kelly Hart of www.NaturalBuildingBlog.com have helped to develop these guidelines. We welcome more comments and help, including engineering advice to identify risk levels for each technique.

Appropriate Non-Engineered Buildings:

In earthquake regions people need buildings, and earthquakes don't happen all that often. It is a difficult decision how strong to build. Check to see the level of earthquake risk for your building site, to make an informed decision. Appendix A has a sketch map for Nepal and links to better information.

These guidelines only apply to single story buildings of 300 m²/ 3300 sf maximum area. The longest side must be no more than 2.5x the length of shortest side. The roof must be light-weight; no clay tile, slate or earth. Roof spans must be 5.5 m/ 18' or less. Gable walls or chimneys above the bond beam level must be built of light-weight materials.

Small houses with rooms of 3 m/ 10' maximum may be safe in higher risk areas than shown for each reinforcement type by these guidelines. High wall density (square area of walls/ overall building area) is strong.

Soil Conditions

Earthbag buildings weigh much more than concrete block or brick. Where subsoil is easy to dig, talk to an engineer. You may need wider footings, and you may need to greatly increase the strength of the building.

If your building is located on bedrock, or shallow firm soil above bedrock, it may receive less quake vibrations than normal soils in your area. This can reduce quake risk levels as much as 20- 25%.

Bracing Walls

Bracing walls or buttresses are perpendicular to longer building walls. Interior earthbag walls function as braces if their doorways are at least 1.2 m/ 4' away from the corner.

**BUILDERS AROUND THE WORLD
NEED BETTER EARTH BAG
INFORMATION.**

**Build Simple Inc. needs help testing
and planning guidelines. Together
we can provide safer answers for
cheap, sustainable shelter to the**

Don't build buttresses sticking out more than 1.2 m/ 4' from any wall. Walls are strongest in earthquakes when attached to other walls at both ends.

Materials

Bags: strong, new or not exposed to sunlight, 46 x 76 cm/ 18" x 30". Long bags are much easier to overlap.
Options: Tubes may be used for foundations, or the lower half of curving walls with separate roofs.
Smaller bags of 38 x 60 cm/ 15 x 27" may be used for Type D construction.

Barbed wire: 12.5 gage, 4 point

Rebar: deformed type steel

Earthen fill: Must be damp when tamped. Fill must contain enough clay, lime or cement stabilizer to harden into a solid block after tamping in bags or tubes. Cure several test bags and remove the bag. Soil should be solid and not deeply cracked.

Portland cement: high quality mix and clean water and aggregate. Shake or vibrate so concrete settles well around reinforcement. Always cover reinforcing steel by 1" minimum.

Construction Methods

This booklet introduces several new reinforcement techniques. More complete instructions for building Type B, Type C, or Type D will be posted online as soon as available.



Some limited information about basic earthbag construction methods is included in Appendix B. The reinforcement level descriptions are based on these basic methods.

For short visual introductions to building with earthbag see Build Simple's Earthbag Info series, found online at <http://buildsimple.org/earthbag.php>.

BSI also highly recommends Owen Geiger's Youtube video clips on his naturalhouses channel and his ebook Earthbag Building Guide: Vertical Walls Step by Step. See more information at <http://www.naturalbuildingblog.com/owens-book-dvd/>.

The print books about earthbag building by builders Hunter and Kiffmeyer and by architect Wojciechowska are also excellent. But keep in mind that reinforcing earthbag for seismic risk is a brand-new field. Build Simple specializes in these innovations and posts the most accurate information as it becomes known.

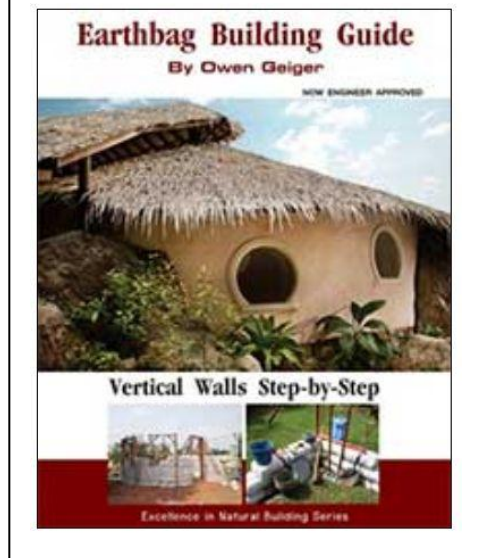

How Much More Does Better Reinforcement Cost?

Our model building is 4m x 6m/ 13' x 19'8", with an interior space of 23.2 square meters (250 sf).

Materials	Units	Type A Standard*		Type B Medium		Type C High		Type D Extra	
		Amount	Local Cost	Amount	Local Cost	Amount	Local Cost	Amount	Local Cost
Solid poly bags	each	890		990		930		860	
Solid poly tubes 38/ 15"	meters			130		130		110	
Barbed wire (4 point)	meters	820		1100		1010		940	
Earthen fill (bags, floor)	meter ³	24		27		25		19**	
D12/ #4 half inch rebar	meters	110		160		130		180	
D9 /#3 3/8 inch rebar	meters					32			
Bags of Portland cement for building and stucco	43 kg/ 94 lb ea	4 bags		23 bags		41 bags		39 bags	
Other materials		Wood for lintels		Some mesh, wire		Geo-mesh 2 courses, wire			
<p>*Type A calculated with 2.7 m high walls although taller are shown in sketches that follow.</p> <p>**Type D is calculated with thinner 33 cm/ 13" thick walls.</p>									

Reducing Costs

Where rebar is too costly, it may be possible to build Type C or D with exterior vertical bamboo. Wire ties should be used, and closer vertical spacing. Bamboo can decay, and should always be left exposed between panels of lime or earth plaster so it is obvious when it needs replacement.

BSI prefers to recommend sustainable earthen and lime plasters instead of cement stucco. But for high seismic risk areas, the added strength of cement stucco may be critical. Until we know more, we recommend cement.

Interior plaster mesh and cement stucco for reinforcement can be delayed if the concrete is too costly. A thin stabilized earth can protect the surface until the mesh and cement stucco can be added in future. This would save 7 bags of Portland cement for Type B, and 15 bags for Type C and D.

Type A:

Standard Reinforced Earthbag

2 STRANDS BARBED WIRE
STRAPPING EVERY OTHER COURSE
BRACING @ 4.5 m
INTERIOR VERTICAL REBAR @ 1.2 m
EXTERIOR PLASTER MESH

Type A is the standard earthbag used in low risk zones.

Because Nepal's quake risks are for motion 1.5- 3 times as severe as that experienced in the recent quakes, we encourage builders in Nepal to **consider using stronger earthbag reinforcement, Type B or better.**

PLAN

90 cm/ 3' minimum between openings or openings and corners.

Maximum opening width 1.5 m/ 5'.

Bracing walls and/ or buttresses every 4.5 m/ 14'9".

Buttresses extend 60 cm/ 24" minimum from walls.

Maximum wall heights for small earthbag buildings could be as much as 3 or 3.3 m/ 10'10" although lower wall heights are safer in seismic risk regions.

4 m x 6 m example Type A building right and below

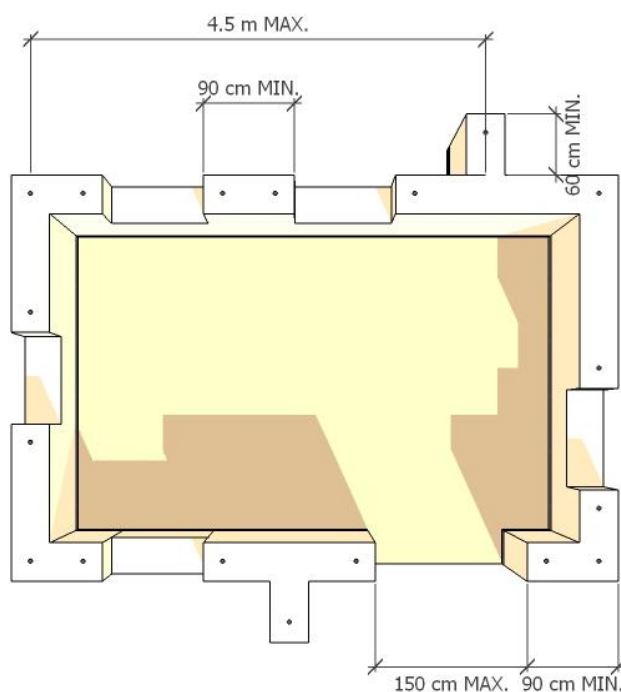
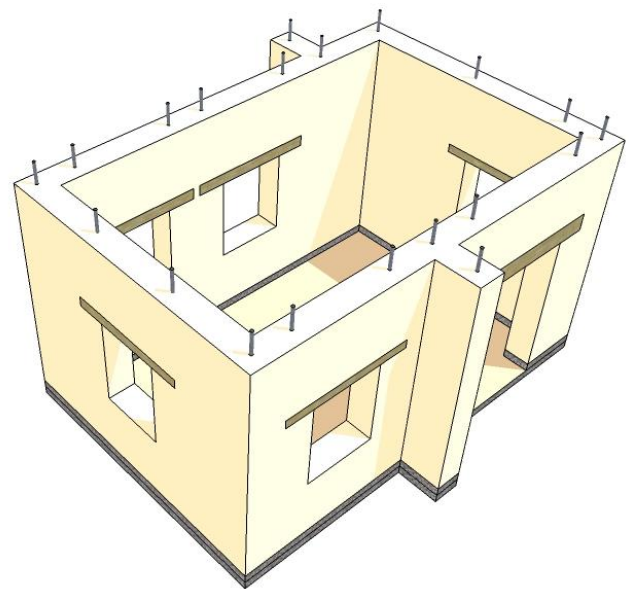

WALLS

Gravel bag foundation to at least one course above interior floor level.

Barbed wire is continuous around each corner. Use 2 pins cut from wire mesh at barbs on each wire near each corner. (see at right)

Engineers point out barbed wire turning corners is one of the weakest points of earthbag walls. Pins cut from wire mesh are a simple solution to help anchor the barbed wire to bags above and below at these stress points].

Barbed wire attaches well to bags of tamped cohesive soil. It does not attach strongly to gravel bags. Every fourth bag add either strong cord ties between bags to wire on the next course, or chunks of cement mortar between bags on the barbed wire.

REINFORCEMENT

Drive vertical rebar reinforcement in every 1.2 m/ 4' along the wall minimum in soil filled earthbags.

Lintels over doors and windows of wood or metal extend 40 cm/ 16" into the walls on both sides.

BOND BEAM

Use a concrete bond beam at least 2/3 as wide as the bag wall and 13 cm/ 5 inches deep (not deeper- to allow it to flex vertically in an earthquake). It must include the tops of buttresses and interior walls. Lay strong mesh across the whole wall top first, for easier stuccoing, and nail the edges of the mesh tight to the upper bags.

Reinforce the bond beam with two D12/ half-inch horizontal rebar continuous, overlapped at least 60 cm/ 2' and tied with strong wire.

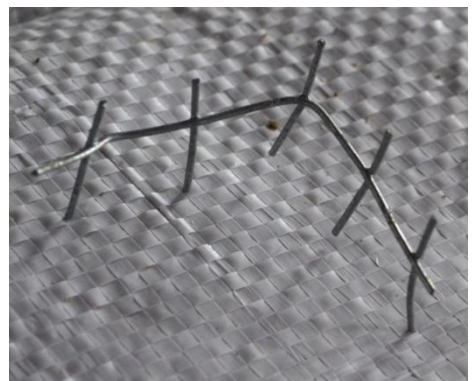

Type B:

Medium Reinforced Earthbag

This type of construction is stronger in earthquakes than Type A. The foundation has some lengthwise strength. But most important, the barbed wire is woven so that walls can't open up at the corners.

For round wall buildings with a separate roof and curved walls from 3' to 20' diameter Type B may be strong enough for medium high seismic risk levels.¹

For straight wall buildings Type B may be strong enough for medium seismic risk levels.

Plan

Maximum wall height 2.7 m / 8'10" to top of bond beam.

1 m / 39" minimum between openings and corners.

Maximum opening width 1.2 m / 4'.

Bracing walls and/ or buttresses at least every 3.5 m / 11'6".

Buttresses extend 80 cm / 31" minimum from walls.

Use piers 1.2 m / 4' high at all exterior corners.

Piers make a thicker wall, usually with a second layer of bags. Alternate bags along walls and through the pier and wall every other course. Weave the barbed wire right through to the outside of the pier. Add more wire along the pier as well. Strap the pier and wall together.

WOVEN BARBED WIRE
TUBE FOOTING
STRONGER EARTHEN FILL
INTERIOR VERTICAL REBAR @ 0.9 m
BRACING @ 3.5 m
HORIZONTAL MESH AT REBAR OVERLAPS
EXTERIOR STRONG CEMENT STUCCO

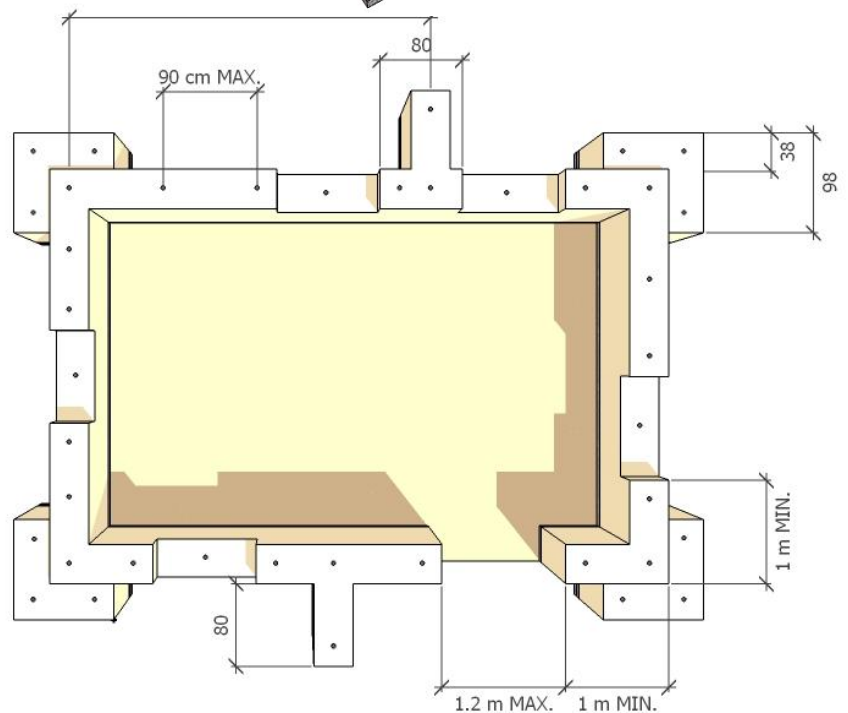
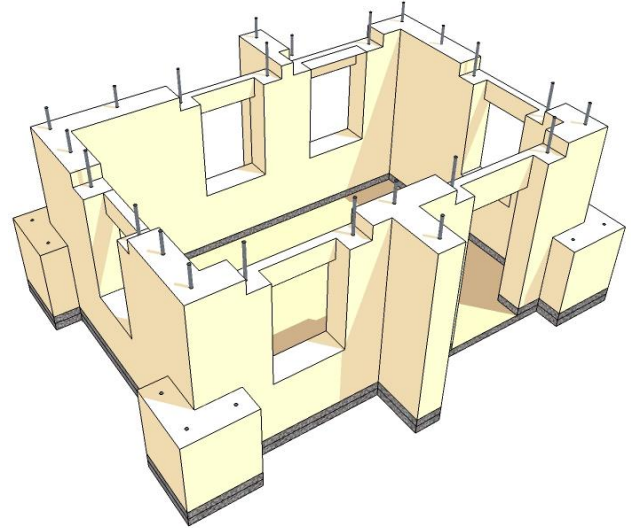

¹ Note: On curving walls barbed wire can only be woven at window and door openings. Build Simple recommends adding pins cut from wire mesh on barbed wire at upper wall levels on round or curving building walls. Curving walls may not need as many buttresses or bracing walls, but including them can increase strength.



Foundation

Gravel Tube Footing

Give the wall a wider first course that is level with the finished grade. 20- 25 cm/ 8- 10" wider than the walls will let the walls above safely move a little.

Use tubes to hold this layer together from corner to corner. Stagger the overlaps at 1.2 m/ 4' or more from corners. Strap rows together firmly. Add another layer of straps under the inside tubes to attach the foundation wall above to this footing.

- 1- Double row of doubled solid poly tubes OR
- 2- Triple row of plastic mesh 'wattle' tubes (see photo and sketch at left)

Mesh tubes are used in the developed world filled with straw or wood chips for erosion control wattles.

Wattle mesh is usually UV resistant and does not need to be doubled to contain gravel. It can be sewn tube to tube with strong cord. Ties and plaster mesh for courses above can also be woven into the mesh at the correct location. When this mesh is covered with cement stucco it forms a strong reinforced cement layer.

Walls

Mix earthen fill strong enough to pass the 50 cm/ 20" drop test:

A cured bag dropped from 50 cm/ 20" height onto a hard surface on its corner does not split in half or lose more than 10 cm/ 4" off a corner. Some added clay (or added sand) will increase strength.

Weave barbed wire at all corners:

Extend both strands of barbed wire 60 cm/ 2' past the end of wall or buttress. Pull straight. (see at upper right)

Weave barbed wire back into wall end above next course (see below right).

Use 4 strong tie wires at each place where the wires cross. Use nails through these wire ties to attach the wire more firmly to the earthbag at stress points.



Tie woven barbed wire around gravel bags:

Extend barbed wire 70 cm/ 27.5" past corners of gravel bags. Because bags do not contain cohesive clay to anchor barbs securely, place first bag of the next course at the corner or end, then pull barbed wire over that bag. Tie the barbed wire end to the still exposed barbed wire on the lower course with wire.

Reinforcement

Horizontal mesh at rebar overlaps:

Use two layers of horizontal mesh to unite lower and upper vertical rebars near middle of walls (see at right).

Three courses below middle height of wall, place continuous strip of strong metal or plastic mesh 15 cm/ 6" wide (not chicken wire). Overlap mesh 30 cm/ 12" minimum. Tie with 2 wires at all overlaps. Nail in place at ends and along edges. Attach to barbed wire with wire ties every 60 cm/ 2' minimum.

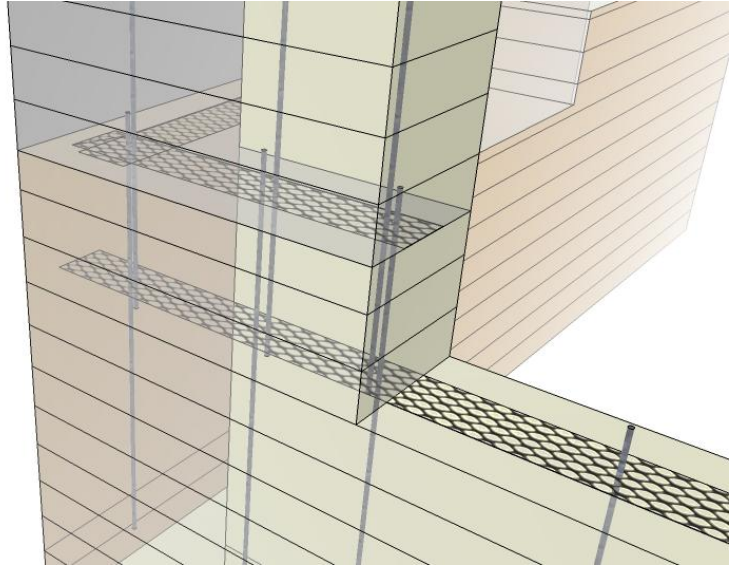

Hammer rebar verticals in at the middle height of the wall every 90 cm/ 3' horizontal minimum. Leave this lower rebar extending 5 cm/ 2" minimum. Place a second layer of strong metal or plastic mesh over exposed rebar tips along all wall surfaces at mid-height.

When the wall is finished, the upper vertical rebars will pierce this mesh. This horizontal layer will better attach the upper and lower verticals.

Lintels over doors and windows must be part of the reinforced concrete bond beam. Thicken the bond beam and add extra steel for 30 cm/12" each side of opening (see at right).

Use a transom or light-weight infill wall material (wood, light straw clay, or bamboo) above doors and windows.

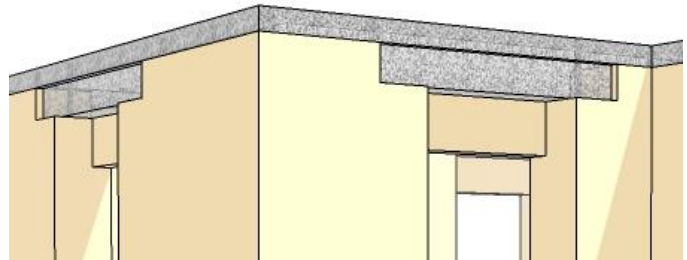

Bond beam

Form and pour concrete bond beam full width of the bag wall and 13 cm/ 5 inches deep. This can flex vertically as needed to survive earthquakes. Thicker is not better.

Plaster

Exterior finish should be strong cement stucco reinforced with poly or fiberglass fibers 2 cm/ 3/4 inch in length. Interior finish can be earthen or lime plaster.

Type C:

High Reinforced Earthbag

This type of construction is stronger in earthquakes than Type B.

For straight wall buildings Type C may be strong enough for medium high seismic risk levels.

Plan

Maximum wall height 2.5 m/ 8'2" maximum including bond beam.

1.1 m/ 43" between all openings or openings and corners.

Maximum opening width 1.1 m/ 43".

Bracing walls and/ or buttresses every 3 m/ 9'10" minimum.

ANCHORED TUBE FOOTING
STRONGER EARTHEN FILL
CORNER VERTICAL REBAR TIED TO
BARBED WIRE
BRACING @ 3 m
STUCCO EXTERIOR & INTERIOR

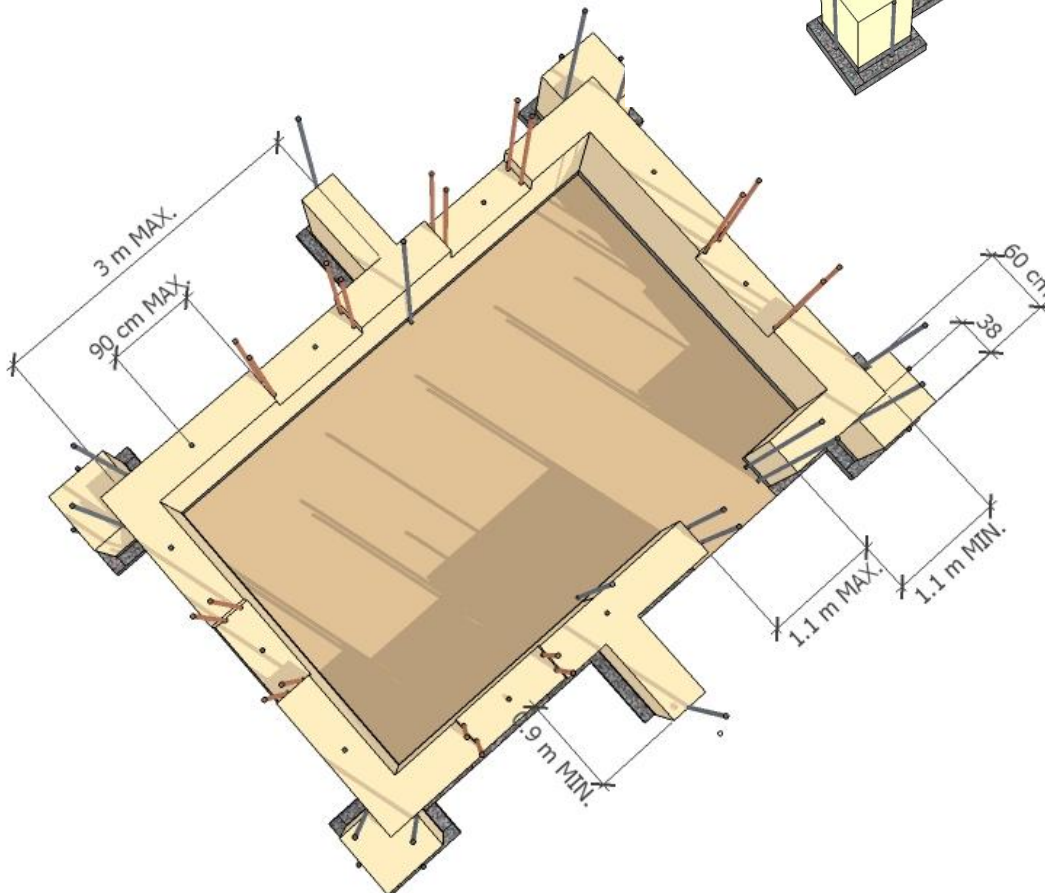
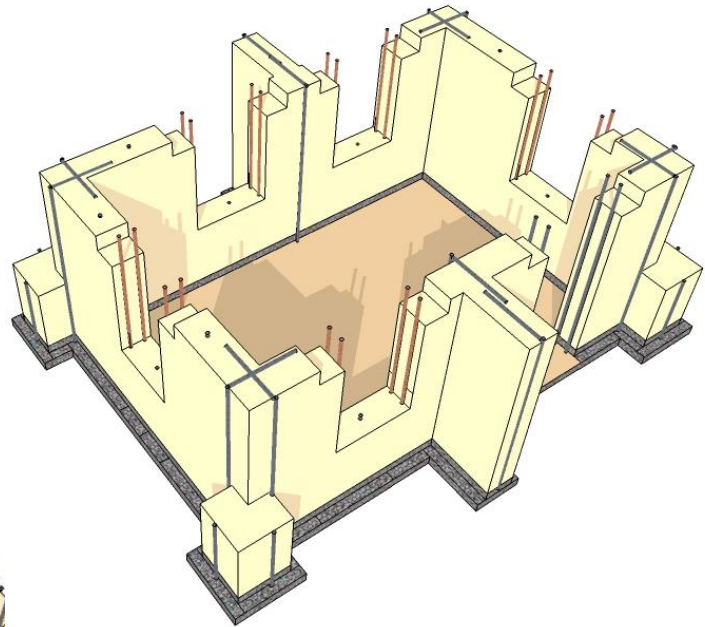

Buttresses extend 90 cm/ 36" min. from walls.

Piers to 0.9 m/ 3' height at all exterior corners.

Vertical rebar are located at exterior corners and openings in line with barbed wire. All barbed wire is attached directly to the rebar for greater strength.

Foundation

Use gravel tube footings as in Type B. But add a low concrete post under the floor level at each corner. Wires are wrapped from these posts around the flexible gravel tube base to limit the distance of motion.

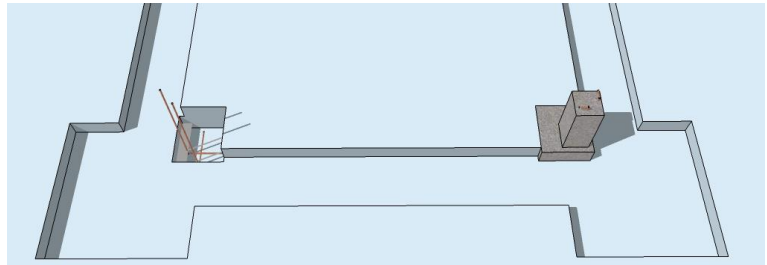

Right: Rebar and formed low concrete post

Add gravel bags to above interior floor level.

Walls

Pour a full-width reinforced concrete grade beam on the top course of gravel bags. All of the exterior vertical rebar must be seated in this grade beam.

D12/ half inch vertical rebars are located 28 cm/ 11" from every exterior corner and centered on the ends of buttresses and opposite walls. Use two D12/ half inch verticals each side of doorways.

Tie vertical rebar together through the wall with strong wire every fourth course. At doorways tie together every other course.

Mix earthen fill strong enough to pass the 76 cm/ 30" drop test:

A cured bag dropped from 76 cm/ 30" height onto a hard surface on its corner does not split in half or lose more than 10 cm/ 4" off a corner.

Attach barbed wire to rebar at all corners and wall ends:

Extend both strands of barbed wire past the end of the wall opening (see at right). Twist barbed wire around rebar and bind with strong tie wire.

Attach at corners as shown below and on next page.

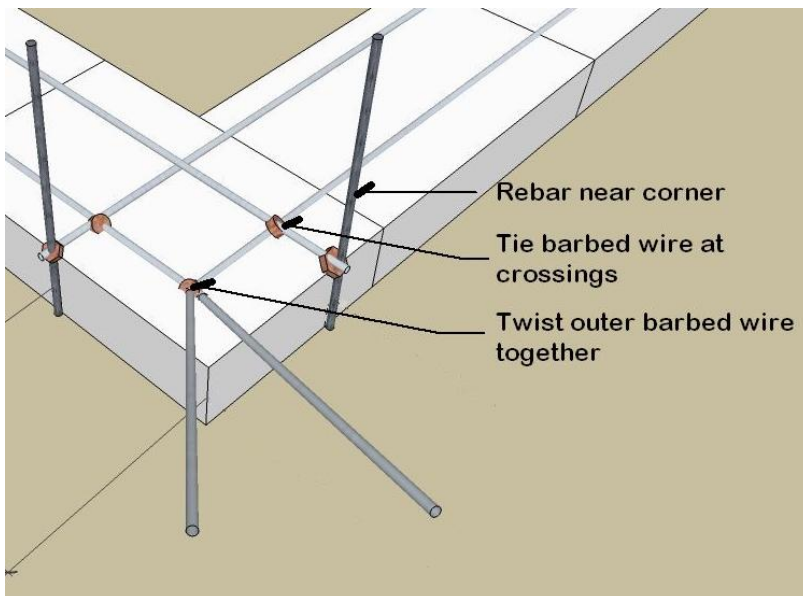
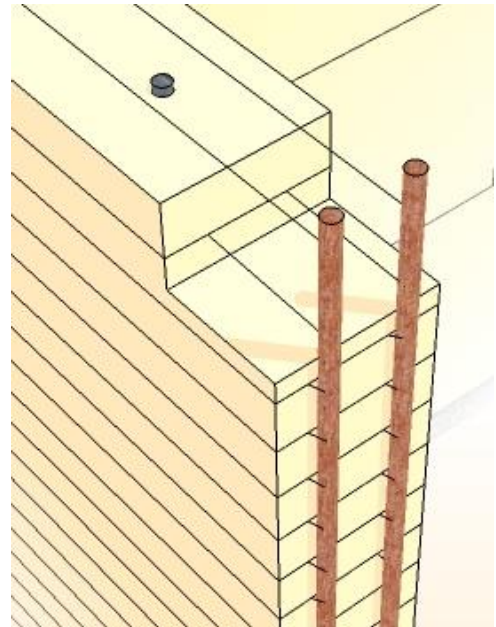

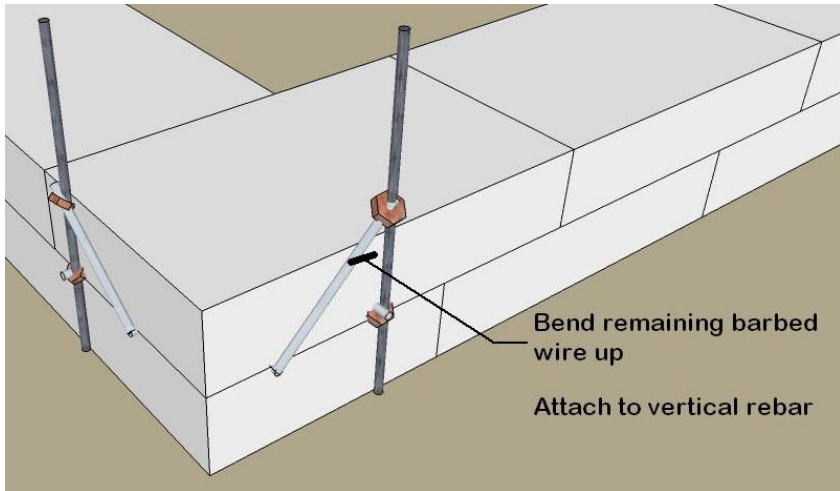

The outer strands of barbed wire at corners bend up to attach to the opposite rebar at the top of the next course. Use pliers and 18 gage wire.

(Red attachments shown at left represent wire binding.)

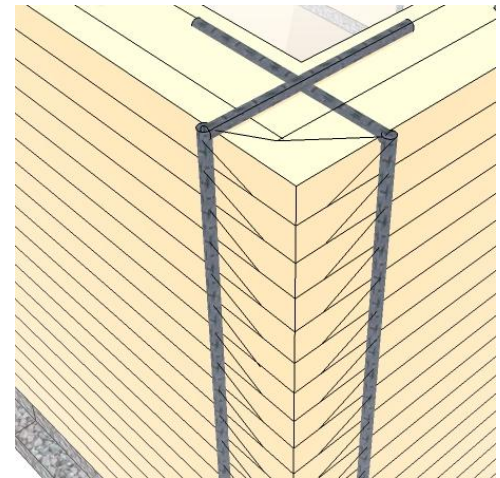

Buttresses have only 1 barbed wire strand tied to rebar at each end. But tie all buttress wires to normal course barbed wire at each crossing.

Horizontal mesh at window-sill level:

On the window-sill course, lay a 25 cm/ 10" wide strip of strong mesh on top of walls under areas planned for inserted rebar. Use two ties and overlap 15 cm/ 6" minimum. Nail it at ends and sides. Attach to barbed wire with wire ties.

Hammer short verticals through the mesh into the center of each window sill.

Then hammer two D9/ 3/8 inch rebars at each side of the window opening to receive upper wall barbed wires. (see below)

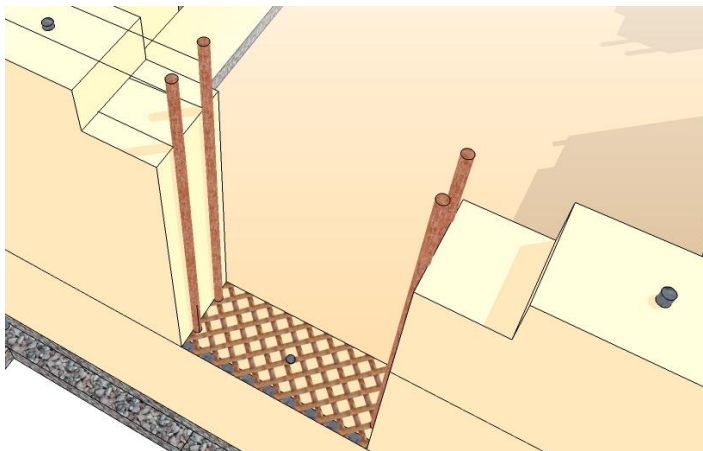

Continue with your bag wall to half height and repeat a second mesh strip. Hammer in lower inserted rebars at least every 90 cm/ 3' between the corner, buttress, and window opening rebar on the outside of the walls.

Bond Beam

Bend exterior rebar in and tie to bond beam horizontals.

Use a full wall width reinforced concrete bond beam with integrated lintels as per Type B.

Plaster

Both interior and exterior wall surfaces should receive a strong cement stucco with fibers.

Type D:

Extra Reinforced Earthbag

This type of construction is stronger in earthquakes than Type C.

For straight or curved wall buildings Type D may be strong enough for high seismic risk levels.

This is a variation of schematic reinforcement developed by Precision Structural Engineering, www.structure1.com. For specific design of an earthbag building in the highest seismic risk regions, engineering help is recommended.

Plan

Maximum wall height 2.6 m / 8'6"

1 m / 39" between openings/ corners

Double exterior vertical D12/ half inch rebar from grade beam to bond beam every 90 cm / 3' minimum with 60 cm / 2' overlap

Hammer in vertical D12/ half inch rebar within

ANCHORED GABION FOOTING
EXTERIOR PINNED VERTICAL REBAR
BRACING @ 3 m
SILL LEVEL RING BEAM
STABILIZED FILL AT STRESS POINTS
STUCCO EXTERIOR & INTERIOR

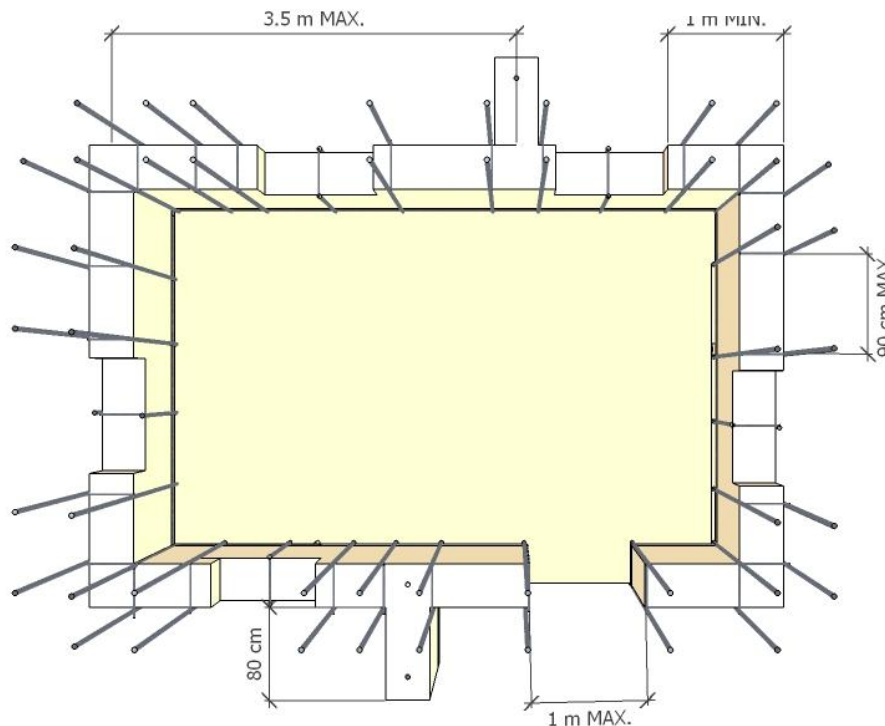
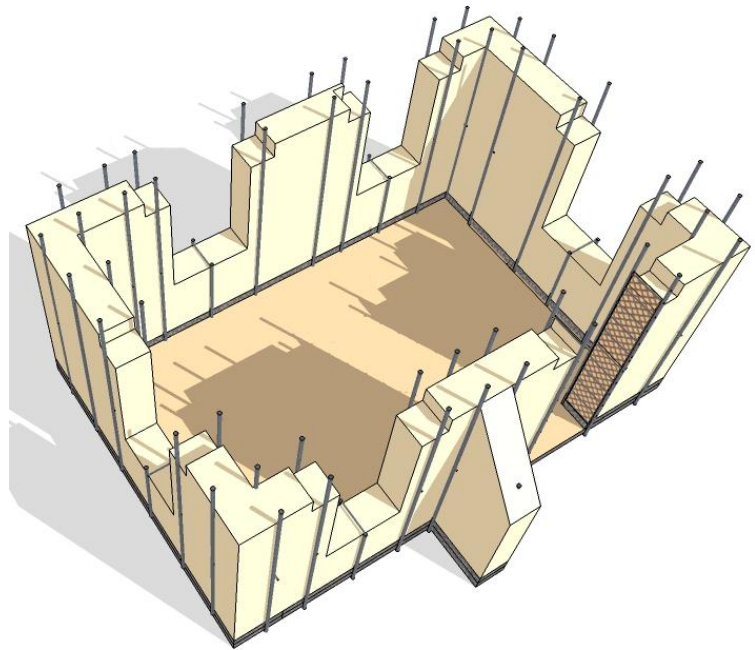

30 cm / 12" of buttress ends

80 cm / 32" minimum buttress length

This type of reinforcement relies on the strength of rebar spanning from a reinforced grade beam to a reinforced bond beam.

Foundation

Although PSE's original design began with a reinforced concrete footing, BSI believes that foundation walls of gravel or small stones provide needed vibration damping in earthquakes.

Either use the anchored gravel tube footing and gravel bag foundation recommended for Type C, or use heavy mesh to create a rock-filled gabion foundation wall. Gabions are metal mesh boxes originally used to stabilize steep slopes or stream banks. They contain rocks and strong rubble.



Above: Gabion wall by Isedlak in the Czech Republic

Wall

This earth wall with exterior rebar pinning every 90 cm/ 3' or closer provides enough reinforcement that a narrower earthen wall may be stable. Narrower walls reduce the weight under stress, and are quicker to build. Use 38 x 60 cm/ 15 x 27" bags to make a 31- 33 cm/ 12- 13" thick earthen wall.

Above the interior floor level, pour a full-width grade beam similar to Type C. Carefully locate all D12/ half inch verticals before pouring. Reinforce with 2 D12/ half inch rebar horiz continuous.

Mix earthen fill strong enough to pass the 76 cm/ 30" drop test as per Type C.

Option: Use a stronger earth fill for bags at stress points (with extra clay or possibly cement and lime). These include the two or three bags at each end of the lowest earth courses on walls, and the upper course. Drive rebar or other anchors in immediately when using stabilized fill.

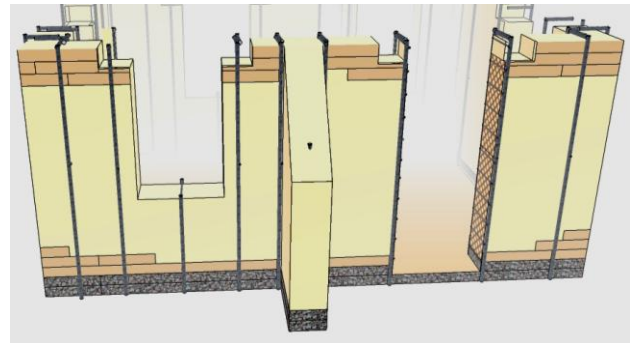

Reinforcement

Heavy ties are needed every third course through the wall between all the opposite rebar.

At doorways the ladder-type ties will be exposed, against the curving bag ends. Add strong mesh tied to the verticals. When embedded in a strong cement stucco, this will become a reinforced concrete doorframe with a strong waffled back side.

Use integral reinforced concrete lintels at door or window openings. At the wall tops, bend rebar in and tie to the bond beam reinforcement.

Bond Beam

Same as for Type C.

Plaster

Use strong fibered cement stucco for interior and exterior. All external rebar must be covered with 2 cm/ ¾ inch of strong concrete or cement stucco.

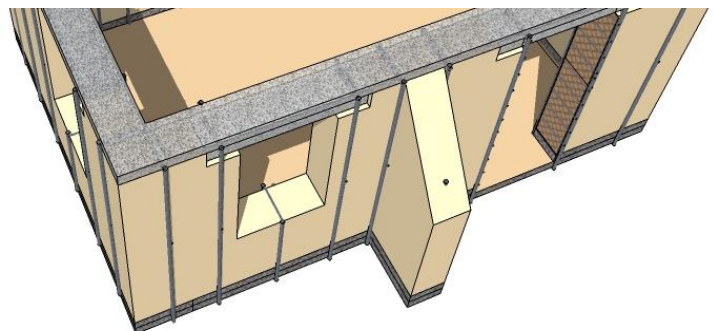

Appendix A

What is my Earthquake Risk?

This rough diagram shows the level of quake motion (peak ground acceleration or pga) that has a 2% chance of happening in any 50 years in central Nepal. It is drawn from online data based on Eurocode 8 and developed in 2010. Newer information may more accurately reflect your site's risk.

The maximum ground motion experienced during the April and May 2015 quakes was more than 0.8 g at some sites. Some earthbag buildings were in areas receiving 0.6- 0.76 g pga. Kathmandu experienced less, but was severely damaged because the deep, soft ground there amplified vibrations.

New Zealand's building guidelines allow unreinforced earth buildings to a comparable 0.56 g risk, and reinforced buildings to their maximum above 2g risk. The standard risk used is for a 2% chance of it happening in 50 years.

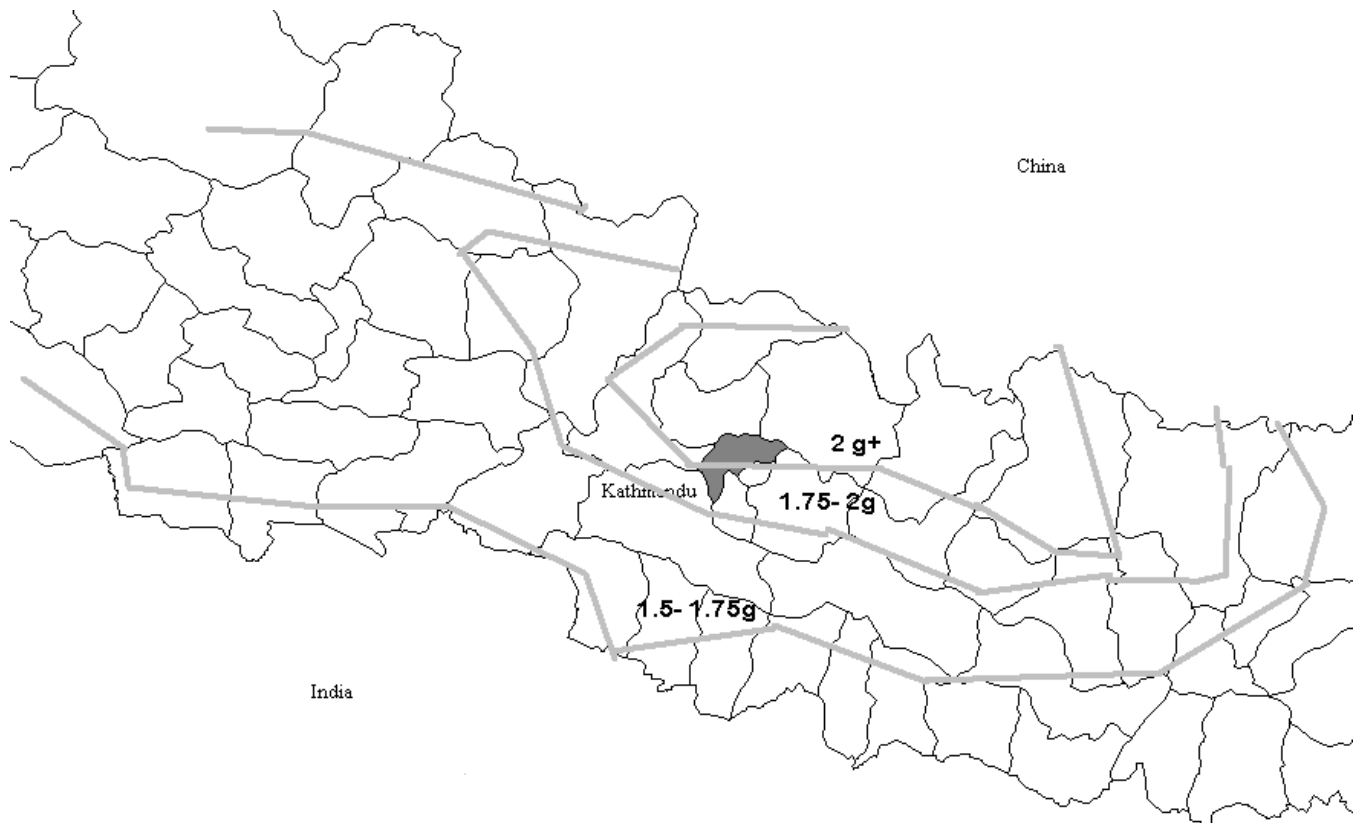

Use the online USGS Worldwide Seismic Design Tool at: <http://geohazards.usgs.gov/designmaps/ww/> to find more exact values. Input latitude and longitude of your site. Or at the first tool window, reset the layers (upper right) to greyscale view. Then drag the marker and zoom in to find your area.

Find the S_s values marked EU Code (or UFC is better if available for your site). Ignore the S_1 numbers.

Discussion of Nepal's seismic hazard in this document uses the 2010 Eurocode S_s values.

More information about earthquake risk levels is included in BSI's online booklet: Rebuilding Nepal Sustainably: Culture, Climate and Quakes, online at: <http://buildsimple.org/resource-lists.php>.

Appendix B

Construction Methods:

Foundation

Start with a trench for rock and rubble, dug deeper than local frost depth. Fill it to 5" below grade. In poorly drained soil or very wet climates rubble trenches must drain to ground surface.

If frost is deeper than 90 cm/36" below grade, use gravel bags or gabions for the below-grade foundation wall.

Rubble trenches and gravel bags or gabions can absorb earthquake vibrations and thus may reduce the stress on the building above by 15- 30%. They also allow expansive clay to expand into the footing air spaces with less displacement and damage.

Reinforced concrete footings cannot flex much and will transmit more vibration to the building. For higher seismic risk levels (Type C and D) buildings can include a reinforced concrete grade beam on top of the gravel foundation walls.

Lay short wire ties or longer 1.7 m/ 5'7" strapping cords under each gravel bag to strap 3 courses together. Always double solid poly bags before filling with gravel.

Bag Walls

Lay individual gravel bags and earthbags in overlapping running bond patterns. Overlap 20 cm/ 8" minimum. Do not locate short bags at wall ends, or directly above each other in the wall.

Build piers and buttresses and wall intersections continuous with walls. Overlap carefully, so at least every other course of bags in the buttress extends through the wall.

Lay two parallel strands of barbed wire along the top of every course. Pull straight. Tie strapping cord to barbed wire every other course. Do not end wires within 1.2 m/ 4' of corners. Overlap barbed wire strands 60 cm/ 2' minimum and attach together with tie wire.

On top of every other course tie 1.7 m/ 5'7" long strapping cords to the barbed wire, one per each bag. Electrician's poly pull cord may be strong enough.

Reinforcement

As soon as wall reaches half height drive D12/ half-inch diameter deformed steel rebar vertically through to top gravel bag at recommended spacing. This is best done into damp, fresh walls. Also drive in rebar within 1 foot of every corner and each side of every window, door, and pier or buttress. After rebar is in place, re-tamp upper course near rebars.

Some techniques that use exterior vertical rebar for reinforcement use little or no inserted vertical rebar. Check your plans carefully. It is difficult or impossible to hammer longer rebars in from the top of a wall.



At full wall height pound additional vertical rebar in similar locations so that they overlap the lower vertical rebar by at least 60 cm/ 2'. Let the upper rebar extend above the upper bags by 30 cm/ 12". Bend ends of rebar horizontal and attach to bond beam rebar. Re-tamp upper course of bags near rebars.

Pound 60 cm/ 2' long rebar pins of D12/ half inch steel at alternating angles into top of wall between other rebar, every 60 cm/ 2' minimum. Leave 10 cm/ 4" showing above bags. Also place roof anchors to be embedded in the bond beam.

Plaster

Use strong plaster mesh, not weak chicken wire. Plastic mesh will survive well in lime plaster or alkaline cement stuccos that destroy metals. Tie plaster mesh firmly to structural members. Overlap plaster mesh by 15 cm/ 6" minimum and tie layers together well. Nail mesh into partially tamped earthbag at alternating angles to allow thinner plaster coating (nails do not add to structural strength).

For Type A- C construction, tie mesh to strapping that is tied to barbed wire.

For Type D, apply mesh under exterior rebar reinforcement and tie with strong cord or wire every 60 cm/ 2'.

Use water-resistant exterior plaster of cement or lime. Apply strong clay plaster containing fibers to the nooks between courses, leaving strapping cord and/ or ties exposed. Attach wire or plastic mesh to both sides of the wall before the cover coat of plaster. Mesh should wrap around the corners by at least 1 m/ 3'3".